

BAT EXCLUSION PROTOCOL FOR BELIZE

Modified from the 2015 protocol created by the Latin American and Caribbean Network for the Conservation of Bats (RELCOM).

This document summarizes guidelines aimed at excluding bats in an effective, permanent, and friendly manner. Bats are clean animals. Unlike birds or rats, they don't build nests or cause damage by chewing through cables or walls. They don't spread diseases through their droppings or the air. The only risk of disease transmission comes from direct bites, which rarely happens unless you try to handle them. Although they pose no threat it is understandable that exclusion from a home may be needed; as long as the recommendations in this document are followed correctly, bats will be effectively removed and unable to return. The aim of this document is to encompass a wide range of scenarios, considering the diverse materials and construction methods found in buildings across Latin America.

These methods can be carried out by anyone at home, but if the problem occurs in public buildings, schools, or sites declared historical or of cultural heritage, as well as in buildings with deterioration, or that house numerous colonies of bats, the task must be carried out by professionals familiar with this protocol. We strongly recommend that the executing companies, and the personnel who will carry out the task, follow the suggested guidelines.



INDEX

General information on bats	3
Harmful methodologies WE DON'T RECOMMEND as exclusion methods	4
1. Toxins	4
2. Ultrasounds	4
3. Smoke	4
Exclusion methodology WE RECOMMEND USING	5
Models of safe exclusion methods	7
Mosquito nets, curtains and roll covers (Figs. 1 and 2).....	7
Mosquito nets (Fig. 1)	7
Curtains (Figure 2)	8
Rollcovers	8
PVC pipes (Figs. 3, 4, 5)	9
The bat scarer	11
Alternative Methods	12
Bat exclusion devices for purchase	13
What to do when a bat enters the house	14
What to do when you interacted with, or found a dead bat	14
Dead animal	14
Live animal.....	15
Bats in caves	15
Alternative shelters	16
If you want to keep them on your property	16
If you want to exclude them from your building but keep them on property	16
Bat House Building Guide	17
Methods for the exclusion of bats and their effectiveness	18
REFERENCES	19
Acknowledgments	19



General information on bats

Bats, what you need to know. Different species of bats that form family groups or colonies can use human constructions as resting, breeding, or hibernation sites. Some people have difficulty co-existing with bats due to noise, smell, and at times deterioration of materials, but in many cases, bats are often feared due to false beliefs, myths, and lack of information. Bats are not aggressive or dangerous animals. Bats do not spread disease through their droppings or airborne particles. While they can potentially transmit Rabies like many other mammals, it's crucial to emphasize that the likelihood of this is very low unless direct contact or handling of an infected bat occurs.

The presence of bats is necessary in cities and fields since they play a key ecological role and benefit humans in many ways. At least 75% of bat species feed on insects, and for every 100,000 bats, 1 ton of insects is consumed nightly. This makes them indispensable for agriculture and pest control. Their value as controllers of arthropod pests has been calculated at several hundred thousand dollars per 100 km² of crop land, substantially reducing the costs allocated to the use of pesticides and reducing the consumption of foods contaminated with agrochemicals. Additionally, their guano can be harvested and used as fertilizer as it is the best fertilizer in the world.

The bats that do not eat insects in Belize are usually fruit eaters and nectar feeders making them important for seed dispersal and pollination. There are many plants like chocolate, agave, and piper that rely on bats for seed dispersal and pollination. Very few species are carnivores, and there are only a couple of species of blood feeders (vampire bats); one of them feeds exclusively on the blood of birds. Vampire bats that do feed on mammal's blood comprise only 1 out of the almost 80 species of bats in Belize.

Bats, being mammals, give birth to live young. They reach sexual maturity after their first year and undergo relatively long pregnancies lasting between 3 to 6 months. Almost every species of bat can only give birth to one pup per year. The timing of their reproductive period varies among species, but commonly, births occur at the end of the dry season and beginning of the wet season. Baby bats are born relatively large and can weigh a quarter to a third of the mother's weight. Most bat pups can fly after just 6 weeks of being born. Bats are extremely long-lived creatures that can live up to 15 to 60 years depending on the species. Consequently, harming bats can lead to detrimental population declines and devastating cascading effects.



Harmful methodologies *WE DON'T RECOMMEND* as exclusion methods

Some commonly used practices that are not acceptable within this protocol

1. Toxins

The use of toxins as an exclusion method is unacceptable, under any circumstances. Toxic substances, usually used to remove colonies or groups of bats, cause great mortality of bats, and can be highly dangerous for human health. These substances often even cause an opposite effect from the desired one, because dying and intoxicated animals can fall to the ground, increasing the chances of contact with pets and people.

2. Ultrasounds

The use of ultrasound, sirens or lights may not effectively deter bats. At the moment, it is understood that these methods only discomfort the animals without fully or permanently excluding them.

3. Smoke

The use of smoke or substances with similar characteristics is also not effective in permanently excluding bats. On the contrary, substances that seek to scare them away increase the probability of contact with bats that are affected, leaving them within reach of pets and/or people. Additionally, using smoke or flushing them out is often a short-term fix and they will come back or be replaced by another colony of animals (birds, rats, bats, etc.)



Exclusion methodology *WE RECOMMEND USING*

The following bat exclusion methods are to be used with live animals. All personnel handling bats or in close proximity to bats should be vaccinated against Rabies and implement the following Personal Protective Equipment (PPE) measures such as wearing masks, protective glasses, and latex gloves. It is recommended to *not use methods that involve capturing and handling of bats*; to avoid unnecessary risks adhere to the following guidelines:

1. Take into account the biological characteristics and life cycles of bats; exclusion should never be done while there are babies inside the shelter. The reproductive periods must then be considered, which generally occur as follows:
 - a. Reproductive periods are SPECIES-SPECIFIC. Please contact a professional to know more about the species life cycle you are working with and when they breed. But as a general rule, in Central America, insectivorous bats breed during the dry season (April to September) and frugivorous bats can reproduce all year round, with a peak at the beginning of the rainy and dry season.
 - b. If you aren't sure about the species you are dealing with, please contact PCMBE (Belize Bat Conservation Program)/T.R.E.E.S at info@treesociety.org or +501 610-5486 (WhatsApp only) for more information regarding their life cycle and if it is safe to exclude them. Or the Belize Wildlife Referral Clinic at [+501 615-5159](tel:+5016155159) in the case of injured or dead animals that are found. These can be preserved in alcohol (between 70 and 96%) and/or stored in a freezer in a labelled ziploc bag until species ID can be confirmed. The collected specimen can be used to identify the occupant species and help with exclusion timing and details. Pictures of the specimen and especially of its face could also be effective for identification.
 - c. NOTE: When conducting exclusions please note seasonality, occupancy details, and occupant species. Not all species act the same. Some create maternity roosts to care for their young together. For example, females of some insectivorous bat species can leave their young for a few hours in the care of a nurse bat while they go out to look for food. Additionally, not all bats leave the roost at the same time; some even do not leave it all night, especially during storms. It is best to give bats a few days to vacate before sealing the structure.
 - d. NOTE: vampire bats have the ability to walk, run and take flight from the ground. For this reason, you should correctly identify the species of bats that are roosting in your house before thinking of a method to exclude them. Vampire bats can crawl in small openings at the ground level to access their roost.



2. During twilight, the points where the bats come out should be carefully searched; in general, they can be detected by black or brown stains on the ceilings or at the entrances they use to get in. These stains come from the bats' body oils or the buildup of droppings around cracks or crevices where they live. Bats come out in the evenings to feed and there is no danger in observing them up close. All access/entry sites must be located for effective exclusion. Remember that smallest species can fit into a hole just 1.3 cm in diameter (1/2 inch). Common points of entry include cracks and crevices in ceilings and cavity walls, chimneys, open doors or windows, open soffits, missing or misplaced roof tins or sheets, or where plumbing or wiring enters the home.
3. The only easy and acceptable exclusion method is night release with “one-way exits”, that is, allowing individuals to leave, but preventing their entry. The models for the exclusion methods can be found in this document.
4. Holes that are detected, and that are not being used for entry or exit, must be sealed with stucco, expandable polyurethane spray foam, silicones, or similar products, ensuring that the material is of good quality and does not deteriorate. Once all non-entry holes are detected and covered try to seal all exits except for the main 1 or 2 that are being used.
5. In the holes detected as entry/exit holes for bats, “one-way exits” must be placed that can be manufactured; they can be covers, half-shade curtains, mosquito netting, or exclusion tubes (see Figures).
6. Each and every one of the main active openings must be equipped with the exclusion system and remain in place for at least 10 days.
7. The sealing of places occupied by bats can only be carried out in their absence. After the 10-day exclusion, the area of occupancy should be inspected before final sealing of all openings.
8. When it has been verified that the eviction site is free of bats, the original exclusion systems used can be removed, and the opening will be permanently sealed with silicone sealant, synthetic foam, wood, stucco or other long-lasting material for a long-term solution. It should be noted that bats cannot make holes, but rather these are caused by deficiencies or deterioration of construction materials or by movements of the structure. It is advisable to review the treated building in order to replace deteriorated materials that may cause new access over time, and to perform annual maintenance. This maintenance consists of checking that the material used in the plugged holes has not deteriorated, and that no new openings have occurred in the structure.



Models of safe exclusion methods

Mosquito Nets, Curtains and Roll Covers (Figs. 1 and 2)

Mosquito Net

Bats can access crawl spaces through small openings up to 1.3 cm (1/2 inch). When bats fly, they must launch from an elevated position to allow an adequate fall time, picking up enough momentum to initiate flight. This is true for all bats, with the exception of vampire bats that can take flight from the ground and crawl under small openings at low levels.

The devices that are placed must be attached to the top of the opening allowing the bats to fall and fly without problems. Some devices such as mosquito nets, curtains or plastic can be placed in these openings to exclude live animals and prevent their return. All accesses must be treated in this way and unused openings must be sealed in advance.

Figura 1

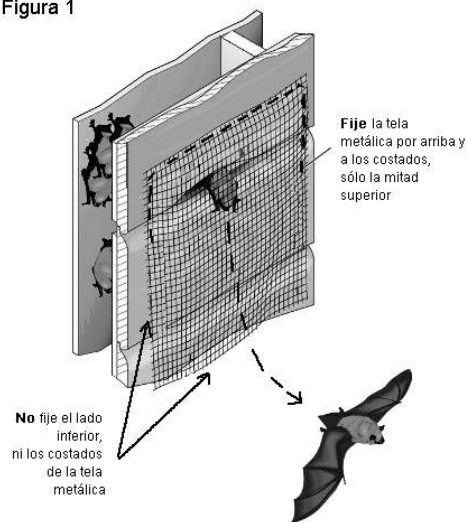

Figure 1: Mosquito Net

When working with smooth wall constructions, a plastic mesh or mosquito-net type mesh can be placed over the openings (with a mesh opening of 0.4 cm, preferably). The mesh is placed over the bat exit opening and then fixed with a button, glue, or with tape. First the upper edge should be attached, followed by the sides (taking care to leave the lower half of the sides and the margin free). The bottom of the mesh, as seen in Fig.1., should extend between 50 and 60 cm below the lower edge of the exit opening and should remain in place for 10 days. It can take a little longer than 10 days when the weather is bad. This procedure must be repeated for each main exit used by the bats. All secondary exits can be covered before the exclusion occurs. This diagram shows a unidirectional exit model, so long as all openings connect to a common internal space. After placing the

mesh, it must be ensured that the bats can get out without problems. If no bats are seen exiting or are seen having difficulty exiting, are seen trapped in the mesh, the net must be adjusted to allow quick and safe exit.

Curtains

An alternative exclusion technique that can also be installed on very smooth surfaces or walls is the

use of a plastic curtain or tight net. These nets are inexpensive, and are commonly used to protect fruit trees from bird attacks. You can also use “half-shade” type fabrics or some plastic with sufficient weight and drape. This device should be placed during daylight hours over the points from which bats emerge. The “curtain” (Fig. 2) must be at least 60 cm (2 feet) wide, it must be placed hanging from a piece of wood (about 2 cm wide) that is fixed above the hole leaving a separation space approximately 2 to 10 cm (1 to 4 inches) from the wall. The curtain should hang at least 30 cm below the lowest point of the outlet (see Fig. 2). This device allows exits but prevents entries, acting as a simple one-way door. In the spring or fall months, wait at least 10 days before removing the “curtain,” making sure that no bats remain inside, and finally proceed to seal the openings. This method is for use in buildings with very smooth walls since bats can climb and re-enter the shelter on rough walls.



Figure 2: Curtains

Rollcovers (Fig. 3)

These are large boxes that are made of different materials (e.g. smooth wood, plastic or aluminum) that serve to cover the entrances and exit points that the bats are using. The system is placed over a opening and uses a roll up blinds system to exclude bats from re-entering. The logic is that the blinds are opened at sun-down to let the bats out then lowered a couple hours later so they cannot enter. This method needs to be used for many nights until all bats are gone because bats don’t need to leave every night and may stay behind. They can be indoor or outdoor and can include small electric motors to automate the opening and closing of the blinds. The curtain will hang above the opening in its entirety, and this being a very smooth surface, will not allow the bats to climb to re-enter. The wall surrounding the box can also be covered by a smooth plastic sheet to prevent bats from climbing up the edges of the walls next to the window. When all the bats have left the shelter, a rubber weather stripping should be placed (taking care that there is no space greater than 1 cm between the weather stripping and the blind) or sealed with expanded polyurethane foam to prevent them from re-entering, or just covered by mosquito netting.

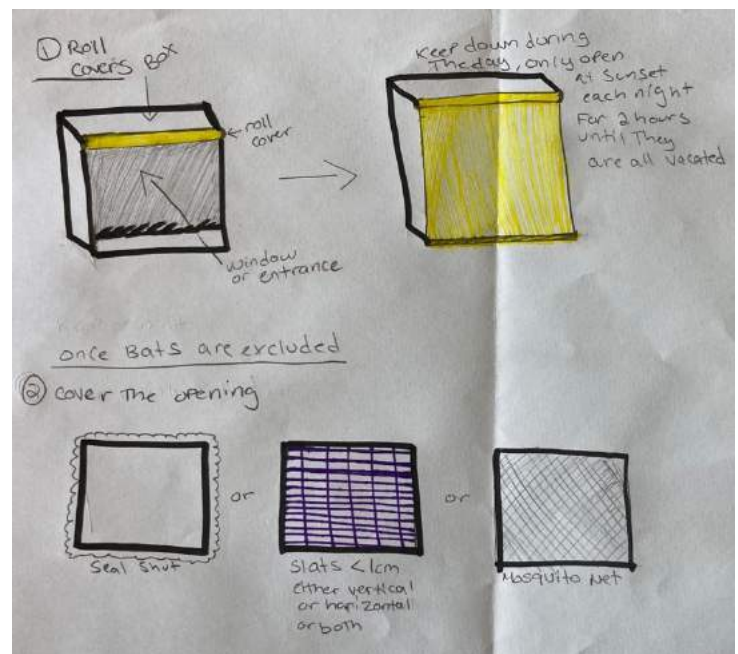

Figure 3: Rollcovers

PVC Pipes (Figs. 4, 5, 6)

In certain situations, for example in buildings constructed of brick, or stone fronts, or wooden huts that provide bats with the possibility of climbing on surfaces, the use of tubes is the more effective exclusion method. The tubes are also effective in openings located in corners, where walls meet, and on horizontal surfaces. The tubes can be made with PVC pipes 5 cm (2 inches) in diameter and 25 cm (10 inches) long, or with plastic bottles with approximate measurements (cutting their ends, base and peak) (Fig. 4). Once the tube is set, glue or tape a plastic bag or a light mesh about 10 or 12 cm long to the end of the main tube.

The tube is placed inside the bats' exit. When placing the tube (Fig. 5 a), be very careful that it does not project inwards more than 6 mm, ensuring that a lip does not form on the inside making it difficult for bats to access the exit tube. Once the tube is fixed in the hole, a polyethylene sleeve can be added to its lower end (Fig. 5 b). This sleeve or external bag allows the “fall”, or exit, of a bat from the inside, but prevents entry in the opposite direction. Since the tubes are so smooth, bats cannot hang or grab and move through them. Once the tube is fixed, any space between the tube and the walls must be carefully sealed (Fig. 5 b). The places to place tubes can be varied, and many times their format must be improvised in order to adapt them to an opening of a certain shape and position.

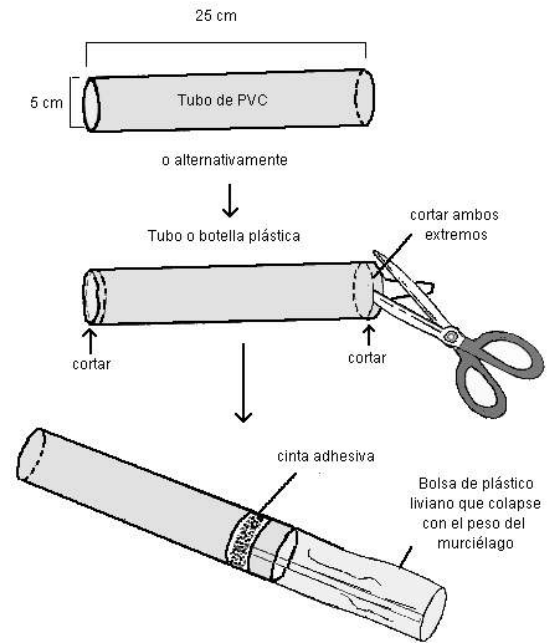

Figure 4: PVC tubes to be cut

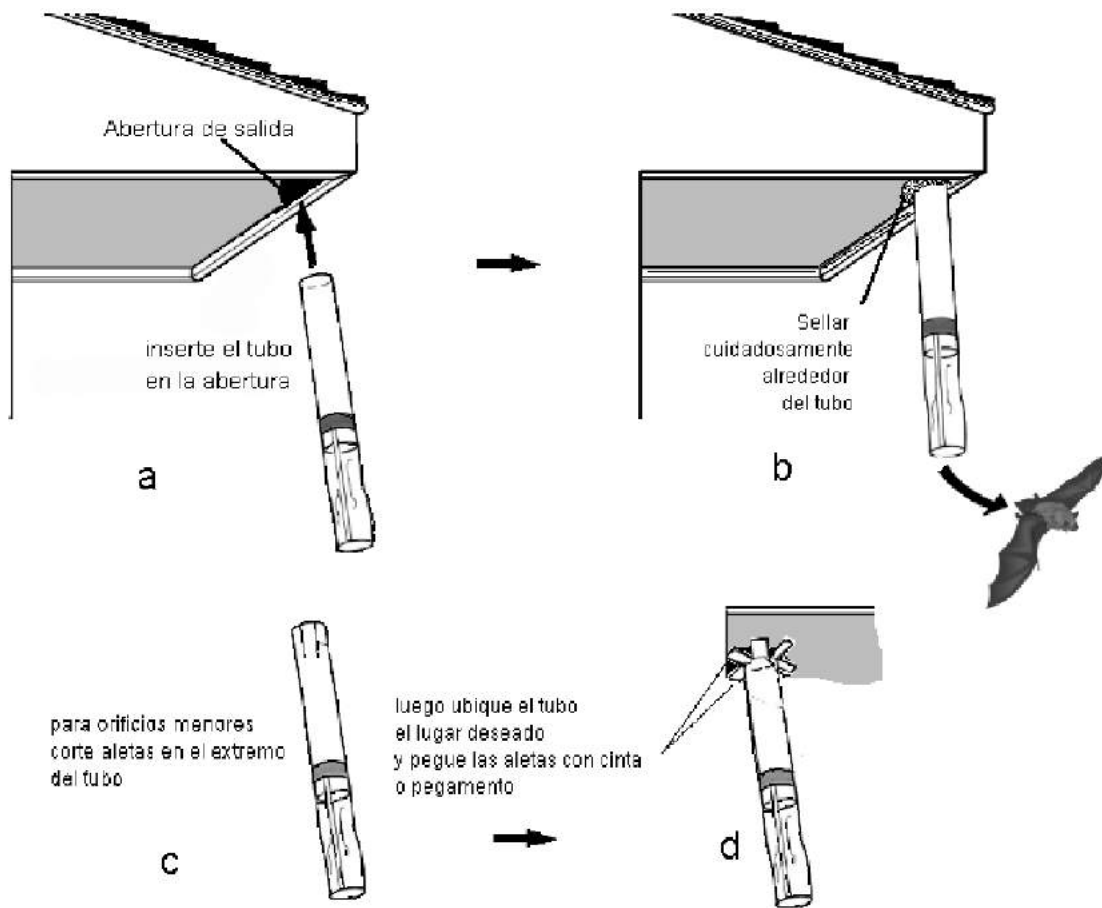

Figure 5: Placing the PVC tubes at the exit of their roost

However, it is necessary to highlight here that an alternative shape that adapts the tubes for different conditions results from making incisions at the end of the tube, opening these incisions to give them the shape of fins, and gluing these with suitable tape or glue (**Fig. 5 c, d**). The plastic tubes just described also work on roofs made of tiles, corrugated iron or zinc sheets (**Fig. 6**). In these, the procedure is similar; first you must carefully observe the points that the bats use as entry and/or exit and place the tubes there, previously sealing other non-used openings. In these cases it is usually necessary to use several tubes. As with the other techniques, any other entrance they may use to enter must be sealed, and the tubes must remain in place for 10 days to ensure that all individuals have exited.

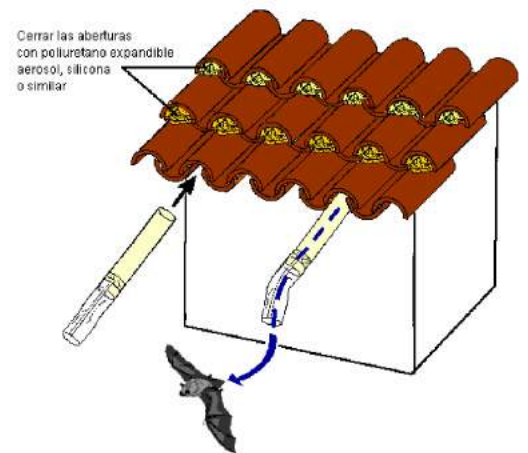

Figure 6: Final result with PVC tubes

The Bat Scarer

This system can be used in places where the precariousness of the buildings and the limited economy of people force us to devise simple and economical methods. These communities, in general, are very remote, making it necessary to propose methods that can be carried out by the population itself without involving high costs or the presence of specialized technicians. This system prevents bats from entering through relatively large openings that are difficult or impossible to cover. This method tries to interfere with the visibility and echolocation of bats as a barrier. At the same time, it is very simple to install and very economical (Lizarro, et al. 2010).

The materials used are tinfoil (which can be found at any market or bookstore), scissors, cutters or knife, and nails, tacks or thumbtacks. With the help of scissors (knife or cutter) the paper must be cut like a fringe without completely separating the strips (Fig. 6). This type of curtain with fringes should be placed in the openings where bats are thought to enter and should be fastened with nails (thumbs or tacks) (Fig. 7). It is expected that the tinned paper and its movement, due to wind or breezes, interfere with the vision and echolocation of the bats, preventing them from entering.

This method is particularly important in places such as tropical forests, where buildings tend to have very large openings to avoid excessive heat and humidity. In this type of environment, it is impossible to close the openings in the ceilings or walls. The bat scarer should be used in openings that are impossible to close, placing fine mosquito mesh to cover the openings, and in this way prevent from settling in. The bat scarer has shown very good results in deterring bats from entering the house, it can have a long-lasting effect on bats (up to 20 years).

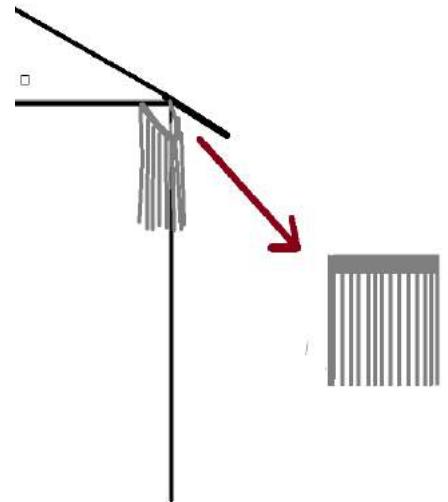

Figure 7: Final result with PVC tubes

Alternative Methods

There are scenarios where more creative methods are required, or multiple animal exclusion is needed. Figure 7 displays a wire spike method which uses wire spikes as a tool to exclude bats, birds and other critters. This method, while effective, isn't preferred as it may cause harm and should only be used as a last resort.

Line the structure or area with angled spikes as seen on **figure 8a**. Blunt spikes are preferred to reduce harm, and can be lined in rows (**Figure 8b**). Although this might accidentally hurt a few bats initially if they're not careful, it's usually non-lethal and deters bats from attempting to roost there. To reduce the chance of harming bats, ensure the spikes are at least a quarter-inch in diameter and not overly sharp. It's important to note that this method also works for excluding birds.

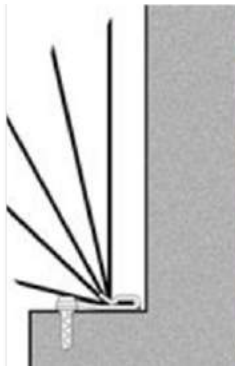

Figure 8 a



Figure 8 b

Bat Exclusion Devices for Purchase

If you have the money or lack time you can purchase devices specifically made to exclude bats from structures

Chimneys or open vertical structures



Funnel



Bat Screen



SPECIAL CONSIDERATIONS

What to do when a bat enters the house.

1. Stay calm; the bat is likely just disoriented and seeking an exit.
2. Close all doors leading to other rooms and bedrooms to confine the bat's movement.
3. Open windows/doors to the outside and turn off bright lights to encourage the bat to fly out.
4. Be patient and allow the bat time to find its way out.

If the bat doesn't leave on its own:

5. Check the bat for any signs of injury or distress.
 - a. If the bat appears injured or unwell, contact a wildlife rescue organization immediately:
Belize Wildlife and Referral Clinic: +501 615-5159
 - b. If the bat isn't injured, give it more time (all night), it will leave eventually.
6. Call PCMBE (Belize Bat Conservation Program)/T.R.E.E.S at info@treesociety.org or +501 610-5486 (WhatsApp only) for more information regarding the identification of the species. Or the Belize Wildlife Referral Clinic at [+501 615-5159](tel:+5016155159) if the bat hasn't left the inside of your house after implementing step 1 to 4.

What to do when you interacted with a live or dead bat

In the case of recently dead bat specimens (range of 24 hours), or live animals that are presumed to be sick (active during the day, on the ground or excessive salivation) and that there has been direct contact with humans or pets (bites, saliva, consumption of bats by pets), you should proceed as follows:

Dead animal

1. Use a long object to gently probe the dead animal to make sure it is in fact dead.
2. Put on surgical gloves or garden gloves on to avoid disease transmission.
3. Place the DEAD animal inside a plastic bag, ideally double bagged, or in a styrofoam/plastic container, with enough ice to ensure good refrigeration during transport to the destination. This will prevent putrefaction of the specimen. Remember not to damage the bat's head, which is the most important part for the identification of the species.
4. Attach all the information inherent to the situation in which the animal was found: date and time, exact place (address and number), name of the person who found the animal, the person transporting it, and any other observation or comment that may be of interest, for example if you were in contact with a person or pet.



5. Call **BAHA (Belize Agricultural Health Authority)** at **822-0818** or **Belmopan Ministry of Health Inspector John Bolden** at **+501 613-6209** who can advise you on how to proceed with the people or animals that had contact with the animal suspected of rabies. Ask if the dead animal you have collected can be tested for rabies at their facility.

Live animal

DO NOT EVER TOUCH THE BAT WITH BARE HANDS!!

Please call the **Belize Wildlife Referral Clinic** at **+501 615-5159** who will know to guide you through the steps to take and make sure you don't get in contact with the bat.

Bats in caves

No matter how harmless the simple visit to caves may seem, the intensive practice of this activity can have disastrous results for bat populations. The mere presence of the visitor causes a great disturbance in the bat colony; furthermore, during the lactation season it is common for mothers, when fleeing from visitors, to drop their babies on the ground where they generally die. Faced with this type of disturbance, bat colonies can become smaller and smaller since bats can live between 15-60 years and usually have only one pup per year. The size of the population inside the cave is a factor of great importance for the maintenance of these bat populations since a large number of animals contributes to maintaining an adequate temperature and each bat is not forced to incur energy costs to maintain body temperature.

This does not mean that the caves cannot be visited. However, some preventative measures can be taken to minimize the disturbance caused. Caves with significant bat colonies should be visited as little as possible and never during the reproductive season, which are SPECIES-SPECIFIC, please contact a professional to know exactly when that is for the species present in caves. In Central America, insectivorous bats generally breed during the dry season (April to September) and frugivorous bats can reproduce all year round, with a peak at the beginning of the dry and wet season. When visiting caves with bats, limit your disturbance of the areas they inhabit to the shortest possible time. You should avoid lighting the bats beyond what is essential or making unnecessary noises.



Alternative shelters

For those who wish to have bats as good neighbors and, for example, help control insect populations, help forests seed disperser and pollinators, two options are recommended:

If you want to keep them on your property

If the bats are housed in roof coverings or ceilings that insulate noise and odors, and the construction material is of good quality and does not suffer deterioration, it may not be necessary to exclude the bats. On the contrary, you can generate a pleasant life for them by minimizing disturbance and noise, since living with them is not dangerous. If you do decide to keep them and if the interior of the roost can be easily accessed, it is recommended to do an annual cleaning, preferably during the months of migration, or low metabolic activity, which usually coincides with the cold or winter months. This cleaning consists of removing the guano, or fecal matter, very carefully, using safety elements such as gloves and masks to avoid breathing the dust generated by the cleaning. You can then use the guano as a high-quality fertilizer for gardening or agriculture.

If you want to exclude them from your building but keep them on property

If you choose the exclusion method, it is recommended not to do so without offering them an alternative shelter that prevents them from being left unprotected, or forced to move away. Bat houses are a useful structure that can be fixed on external walls, or on nearby trees, at a minimum height of 4 meters to avoid predators. These artificial houses should preferably be tested a long time before eviction, so that the bats get used to their presence. A wide range of instructions on how to build them and where to place them can be found on various websites such as Bat Conservation Management (BCM), Bat Conservation International (BCI), and The National Wildlife Federation (NWF). Below, you will find a step-by-step method for constructing these houses, as utilized by The Nature Conservancy (TNC) and BatCon below.



Bat House Building Guide

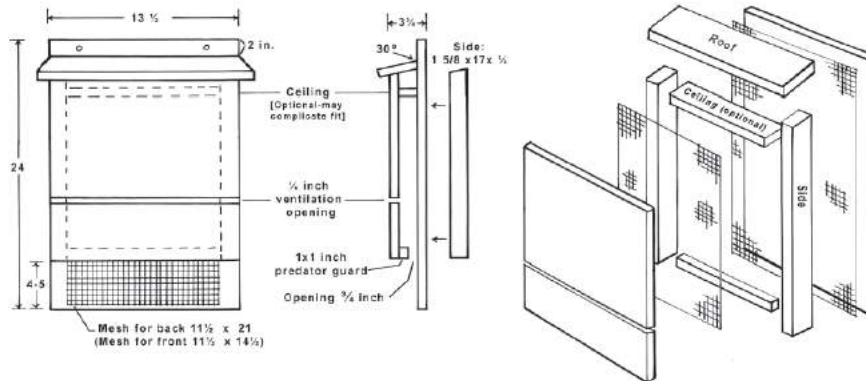

MATERIALS:

- 3/4" to 1" thick exterior plywood or cedar
- Galvanized screws
- Silicone caulk
- 1/2" to 3/8" staples
- 1/8" to 1/4" polyethylene plastic mesh (optional)
- Non-toxic, black or brown latex paint (optional)

FINISHED SIZE:

- At least 24" tall
- 13 – 14" wide
- 3" – 4" deep

BUILDING RECOMMENDATIONS:

- Inside should have horizontal grooves at least every 1/4" to 1/2" apart OR attach polyethylene plastic mesh with exterior staples all the way up the front and back on the inside of the house to ensure bats can hang comfortably
- Opening at the bottom of the house should be about 3/4" to 1" wide to prevent predators from entering
- Use 2" width sides and a 1" strip of wood (predator guard) attached to the lower front panel to create the small opening
- Landing area should be at least 4"

- For temperature variation, add a ceiling just beneath the roof on the inside of the house and leave a 1/4" wide air vent about 6" above the opening
- Caulk the seams to keep bats warm and dry
- Put bat house together with galvanized screws to help prolong the life of the house
- Paint outside of bat house with non-toxic, black or brown latex paint if the house is not getting at least 6 hours of sunlight

LOCATION AND MOUNTING:

- Place at least 15 ft. high
- Face south to southeast to gain exposure to at least 6 hours of direct sunlight
- Bat house should be free from obstructions with at least 20 ft. of open space around the bat house
- Mounting options: poles, garages, barns, human houses, or tall trees, making sure there are no obstacles to prevent bats from entering the bat house.
- Bat houses covered by leaves may take longer to become occupied because they are harder for the bats to find

For more information on bats and how to get involved in our Bat House Research Project, please visit www.batconservation.org or contact the Organization for Bat Conservation at info@batconservation.org.



For more information about bats, visit www.batconservation.org and www.batslive.pwnet.org



ORGANIZATION FOR
BAT CONSERVATION
#SAVETHEBATS



METHODS FOR THE EXCLUSION OF BATS AND THEIR EFFECTIVENESS

Methods	Effectiveness	Adverse consequences
Ultrasonic devices	Temporary	They can be harmful to people and also attract more bats
Naphthalene	Temporary	Harmful to human health.
Artificial light (100-150 watt bulb)	Temporary, and may have a reverse effect (attracts bats to the insects attracted by the lights)	Expensive method, since the lamp must be left on all night.
Burning of tires, paper, plants and oils	Unknown, but likely temporary or only semi-effective	It can cause fires and suffocation deaths for bats that will soon begin to decompose in the roof. The effects are short lived and can affect human and pet health. Individuals who managed to escape will soon settle back in.
Fumigation	Temporarily effective	<p>Risk to human health. Bats that die and remain in the roofs will decompose, generating flies, worms and bad odors.</p> <p>Important!!!</p> <p>The use of pesticides against bats is highly unrecommended and counterproductive, and greatly increases the likelihood of bats coming into contact with humans and pets.</p> <p>Additionally, pesticides have long-term effects on human health that is irreversible</p>
Unidirectional Exclusion	Permanent, safe and cost effective	None
Artificial or alternative shelters	Effective as long as openings in the house where bats could enter are sealed	None
Angled Spikes	Effective long term	May harm birds, bats, and other critters

REFERENCES

Bat Conservation International. 2013. “ *Bats in Buildings , A Guide to Safe and Human Exclusions* ” http://www.batcon.org/pdfs/education/fof_ug.pdf . Reviewed September 9, 2013.

Bertonatti, C. 1996. “ *Bats: guide to knowing and defending bats* ”, Ed. Albatros .

Lizarro , D, MJ Castro, B Mamani , L Beyuma , C Caimani I Moya. 2010. *A proposal to scare away bats that enter houses: “The case of the Colegio de Asunción de Quiquibey RB-TCO Pílon Lajas, Beni – Bolivia ”*. Bulletin of the Latin American Network for the Conservation of Bats. Vol 1, No. 3.

PCMA. 2013. Bat exclusion protocol. Argentine Bat Conservation Program.
<http://www.pcma.com.ar/Protocolo%20de%20exclusion%20PCMA%202011.pdf> .
Reviewed September 9, 2013.

PCMCR. 2013. Bats and Roofs Answer Manual. (Costa Rica Bat Conservation Program).

Acknowledgments

Members of the PCMs have participated in the preparation of the original document printed by The Latin American and Caribbean Network for the Conservation of Bats: Argentina (Mónica Díaz), Bolivia (Isabel Moya), Chile (Renzo Vargas), Costa Rica (Bernal Rodríguez), Puerto Rico (Armando Rodríguez); contributing their experiences and the exclusion protocol developed by BCI (Bat Conservation International) and the PCMA (Argentine Bat Conservation Program) has also been used.

This document has been adapted by Zeinab Rose Haidar and Vanessa Martin.

